



ASTON[®]

YOUR COMPLETE GO-TO MACHINE

ATC-T5 **Smart Solution**
TIRE EQUIPMENT SPECIALIST



Aston Technologies, Inc.
www.astontechusa.com

ATC-T5 SPECIFICATIONS

Rim diameter	12"-30"
Max.Wheel diameter	1200mm
Max.Wheel width	3"-16"
Working pressure	0-13bar
Working Voltage	415V/380V/220V/110V
Hydraulic motor	4.0hp
Max.Flow Of Oil For Hydraulic Motor	315
Net Weight	635lbs./(288kg)
Gross Weight	701lbs./318kg)
	1360×900×1500mm
Loading Quantity	40"HCTNR 21pcs

ASTON®

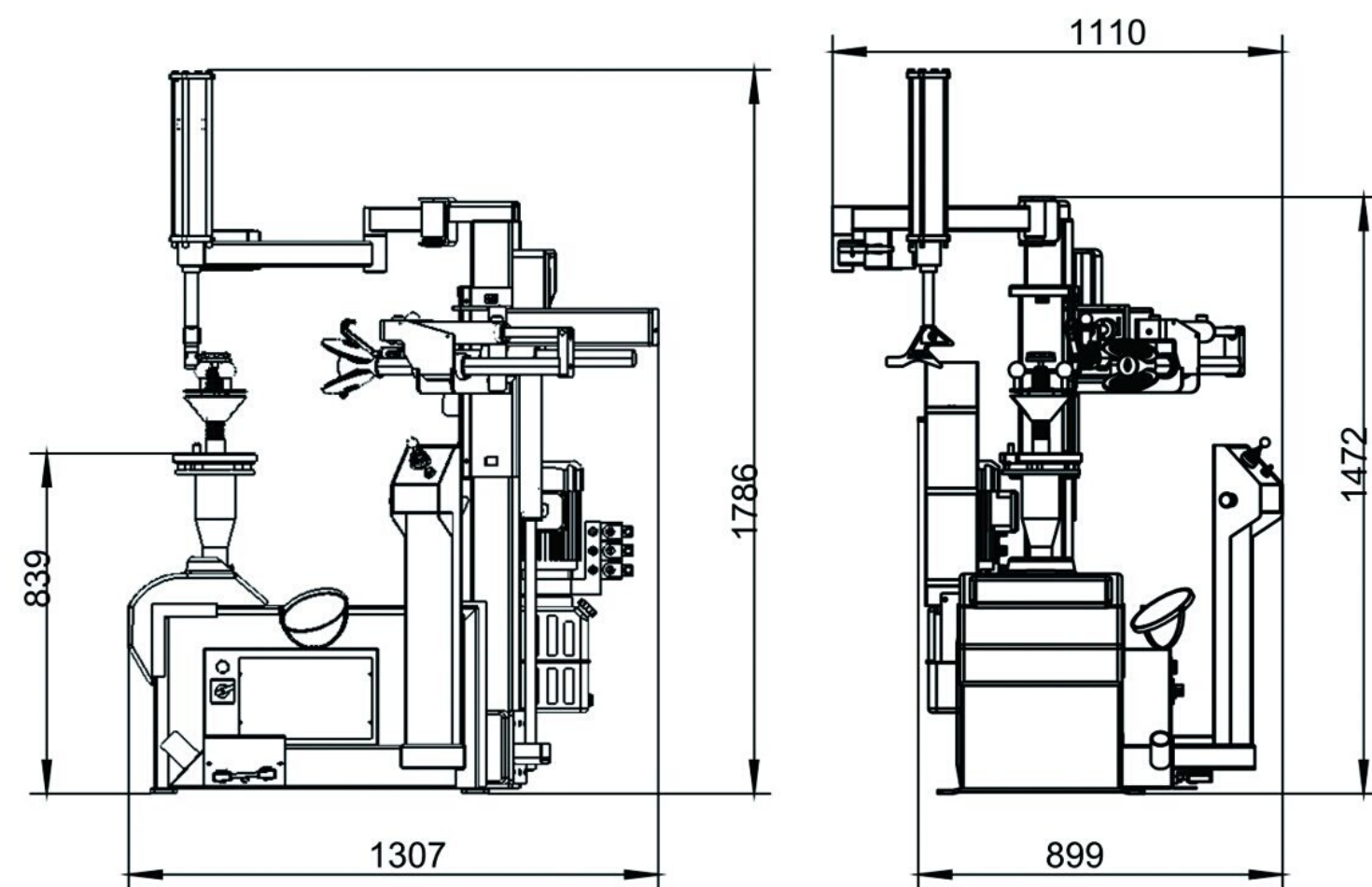

ATC-T5 THE DETAILS OF THE FEATURE

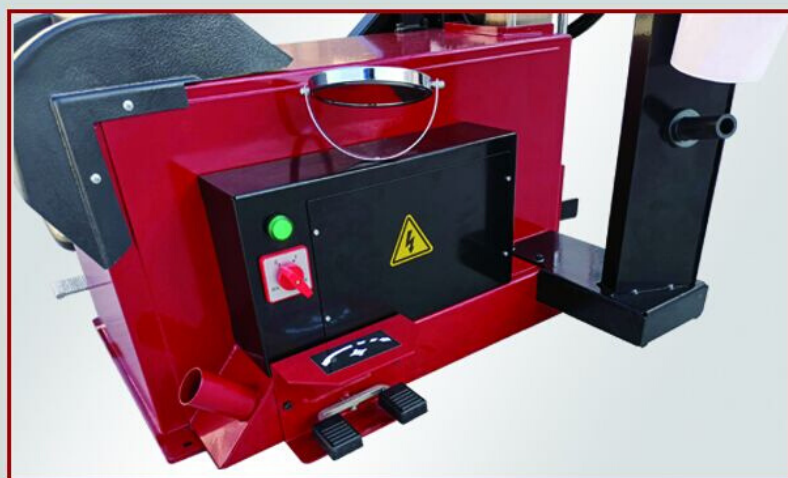

Electric power system turns off automatically when operation is stopped. It is safe, stable, and has a high working rate while being energy efficient.



Two switches control the central column; up and down, working head forward and backward, disc wheel up and down, and disc wheel forward and backward which makes machine easy and comfortable to control.



Central column integration 2.0. Hydraulic system makes it more stable, easier to control and creates a higher working rate. Double disc wheel can both lift and press tires. Automatic operation avoids touching or controlling tires by hand.



Central column integration 2.0 ensures a longer service life

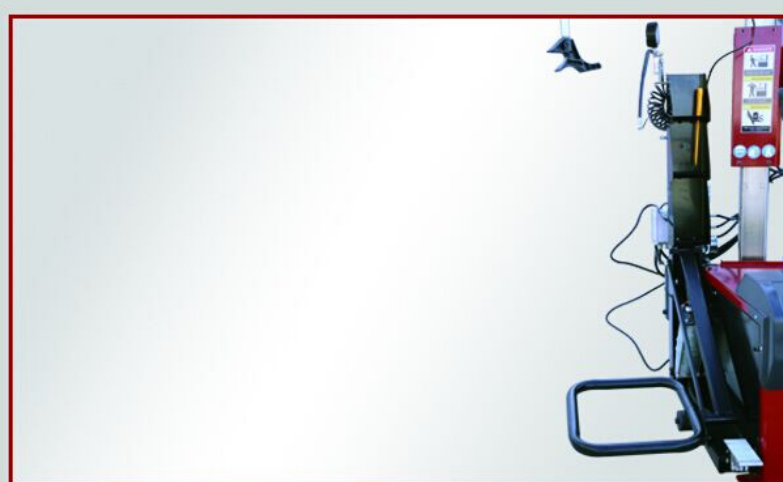

Simple structured tire lifting system, stable, easy operation and a high working rate allows you to work together with machine.

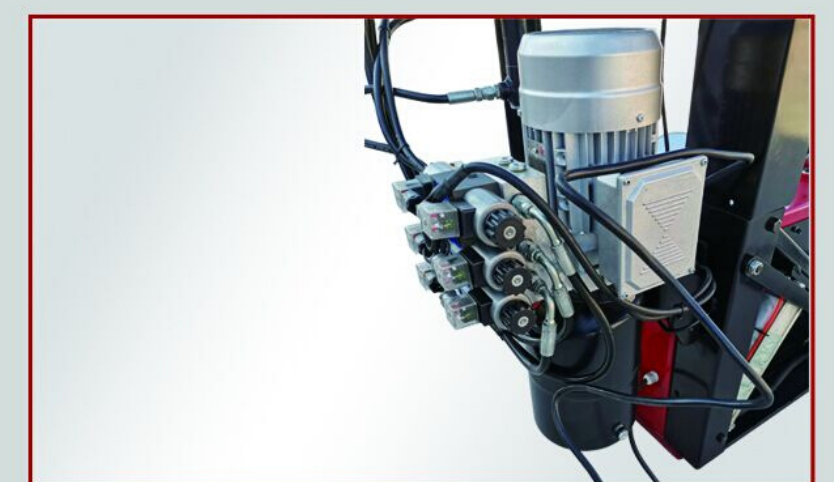

Power hydraulic system works together with electric system, provides much longer service life and a more stable quality than pneumatic system.